

# Evaluation of Fracture Toughness Degradation of CrMoV Rotor Steels Based on Ultrasonic Nonlinearity Measurements

Hyunjo Jeong\*

*Division of Mechanical Engineering, Wonkwang University, Iksan, Chonbuk 570-749, Korea*

Seung-Hoon Nahm

*Nondestructive Measurement Group, Korea Research Institute of Standards and Science, Taejon 305-600, Korea*

Kyung-Young Jhang

*School of Mechanical Engineering, Hanyang University, Seoul 133-791, Korea*

Young-Hyun Nam

*Nondestructive Measurement Group, Korea Research Institute of Standards and Science, Taejon 305-600, Korea*

The objective of this paper is to develop a nondestructive method for estimating the fracture toughness ( $K_{Ic}$ ) of CrMoV steels used as the rotor material of steam turbines in power plants. To achieve this objective, a number of CrMoV steel samples were heat-treated, and the fracture appearance transition temperature (FATT) was determined as a function of aging time. Nonlinear ultrasonics was employed as the theoretical basis to explain the harmonic generation in a damaged material, and the nonlinearity parameter of the second harmonic wave was the experimental measure used to be correlated to the fracture toughness of the rotor steel. The nondestructive procedure for estimating the  $K_{Ic}$  consists of two steps. First, the correlations between the nonlinearity parameter and the FATT are sought. The FATT values are then used to estimate  $K_{Ic}$ , using the  $K_{Ic}$  versus excess temperature (i.e.,  $T$ -FATT) correlation that is available in the literature for CrMoV rotor steel.

**Key Words:** Rotor Steel, Temper Embrittlement, Fracture Toughness, Fracture Appearance Transition Temperature (FATT), Nonlinearity Parameter, Nondestructive Evaluation

## 1. Introduction

During long-term service at elevated temperatures, many power plant components can be exposed to various damaging processes which can affect their performance. The high pressure and intermediate pressure sections of steam turbines, made from CrMoV steel, are the most

critical components that have a large effect on the safe and reliable operation. Prolonged service exposure of the rotors in the range of 343-538°C leads to deterioration of their toughness, due to embrittlement of the grain boundaries by the segregation of impurity elements present in the steel. This embrittlement phenomenon, commonly known as temper embrittlement, results in a decrease of the rotor life due to increased risk of brittle fracture, and is one of the major causes of early retirement of rotors. Thus, the most important material parameter in assessing rotor integrity is the fracture toughness ( $K_{Ic}$ ), because the value of  $K_{Ic}$  determines the critical crack size for the rotor.

\* Corresponding Author.

E-mail : hjeong@wonkwang.ac.kr

TEL : +82-63-850-6690; FAX : +82-63-850-6691

Division of Mechanical Engineering, Wonkwang University, Iksan, Chonbuk 570-749, Korea. (Manuscript

Received October 30, 2000; Revised December 22, 2001)

The generation of fracture toughness data for in-service rotors is of a primary importance, but direct sampling of fracture mechanics specimens is generally impractical. Therefore, a two-step approach is being used (Viswanathan and Gehl, 1991; Holzman et al., 1996). As a first step, the brittle to ductile fracture appearance transition temperature (FATT) at the critical location is determined by extracting small and simple specimens. In the second step, the FATT results are used to estimate the  $K_{IC}$  values at various temperatures using published correlations between "excess temperature" (i.e.,  $K_{IC}$  test temperature-FATT) and  $K_{IC}$ . Since it is not always possible to take specimens from operating rotors, it is desirable to develop procedures which are relatively nondestructive, to evaluate the rotor toughness. In recognition of this need, a number of methods based on phosphorous content (Viswanathan and Gehl, 1991), small punch testing (Foulds and Viswanathan, 1994; Ha and Fleury, 1998; Shekhter et al., 2000), electrochemical technique (Nishiyama et al., 1994), eddy current examination (Viswanathan and Bruemmer, 1995), and electrical resistivity measurement (Nahm et al., 1998) have been explored.

In recent years substantial work in the application of ultrasonic nonlinear properties to materials characterization has been reported. Ultrasonic nonlinearity in materials is often determined by measuring the amplitude of the second harmonic signal generated when a pure sinusoidal longitudinal wave propagates through the material. Experiments for the quantitative measurement of nonlinearity parameter sometimes with the associated modeling were performed to examine the contribution of applied stress, plastic deformation (Hikata et al., 1965; Jhang and Kim, 1999), micro-cracks (TenCate and Van den Abble, 1996) or fatigue (Yost et al., 2001; Frouin et al., 1999). In addition to these applications, others have used nonlinear ultrasonics to test adhesive joints nondestructively (Rothenfusser, et al., 2000).

In this paper we propose a nondestructive ultrasonic method for estimating the fracture

toughness of embrittled CrMoV rotor steels. The ultrasonic nonlinearity is chosen as the material parameter to be correlated with the fracture toughness. The generation of second harmonic components during the propagation of ultrasonic waves through a degraded material is explained on the basis of nonlinear elasticity. Charpy V-notch impact tests are performed on thermally-aged rotor steel specimens to determine FATT. A new signal processing method using bispectral analysis is adopted for nonlinearity parameter measurement. The nondestructive procedure for estimating the  $K_{IC}$  consists of two steps. As a first step, the correlations between the nonlinearity parameter and the FATT are sought. The FATT values can then be used to estimate  $K_{IC}$ , using the  $K_{IC}$  versus excess temperature (i.e.,  $K_{IC}$  test temperature-FATT) correlation that is available in the literature for CrMoV rotor steel.

## 2. Theory (Hikata et al., 1965; Jhang and Kim, 1999; TenCate and Van den Abble, 1996; Yost et al., 2001)

In order to explain the generation of higher order harmonic waves, consider a single frequency ultrasonic (longitudinal) wave propagating in a degraded material, as shown in Fig. 1. Here,  $A_1$  is the displacement amplitude of the fundamental frequency component,  $\omega$  is the angular frequency,  $k$  is the wave number, and  $t$  is time.

We introduce the nonlinear Hooke's law for the degraded material, whose stress-strain relation is described by

$$\sigma = E\varepsilon(1 + \beta\varepsilon + \dots) \quad (1)$$

where  $E$  is Young's modulus and  $\beta$  is a higher order nonlinear elastic coefficient. If we assume that the attenuation can be neglected, the equation of motion of the longitudinal wave in the material

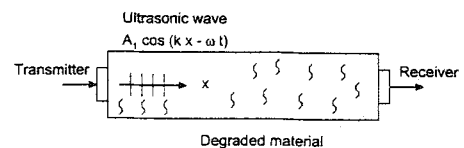

Fig. 1 One dimensional wave propagation in a degraded material

can be represented by

$$\rho \frac{\partial^2 u}{\partial t^2} = \frac{\partial \sigma}{\partial x} \quad (2)$$

where  $\rho$  is the mass density of the solid in the unperturbed state,  $x$  is the propagation distance of sound wave,  $u$  is the displacement, and  $\sigma$  is the stress. Using Eqs. (1), (2) and the relationship between strain and displacement,  $\varepsilon(x, t) = \partial u(x, t) / \partial x$ , one can obtain the nonlinear wave equation in terms of displacement  $u(x, t)$  as follows:

$$\rho \frac{\partial^2 u}{\partial t^2} = E \frac{\partial^2 u}{\partial x^2} + 2E\beta \frac{\partial u}{\partial x} \frac{\partial^2 u}{\partial x^2} + \dots \quad (3)$$

In order to obtain a solution, the perturbation theory is applied. For this purpose, the displacement  $u$  is assumed as

$$u = u_0 + u' \quad (4)$$

where  $u_0$  and  $u'$  represent the initial wave and the first order perturbation solution, respectively. If we set  $u_0$  to be a sinusoidal wave of single frequency,

$$u_0 = A_1 \cos(kx - \omega t) \quad (5)$$

then we can obtain the perturbation solution up to the 2nd order as follows:

$$u = u_0 + u' = A_1 \cos(kx - \omega t) - A_2 \sin 2(kx - \omega t) \quad (6)$$

with

$$A_2 = \frac{\beta}{8} A_1^2 k^2 x \quad (7)$$

The second term in Eq. (6) represents the second harmonic frequency component. As a result, we can explain how the second order harmonic waves of amplitude  $A_2$  occur through the propagation process of nonlinear elastic solid. In addition, from Eq. (7), we can see that the magnitude of the second order component  $A_2$  depends on  $\beta$ , which represents the nonlinear characteristics of degraded material. Therefore, if we measure the magnitude of  $\beta$ , we can evaluate the extent of degradation of property due to high temperature exposure. For constant  $k$  and  $x$ ,  $\beta$  can be normalized as

$$\beta' = \frac{\beta k^2 x}{8} = \frac{A_2}{A_1^2} \quad (8)$$

In this study, the normalized coefficient  $\beta'$  is defined as the ultrasonic nonlinearity parameter, and will be measured experimentally.

### 3. Nonlinearity Parameter Measurement by Power Spectrum

The magnitude of a signal at specific frequency can be conveniently obtained from the analysis of spectral density functions. The power spectral density function of signal  $x(t)$  is given by the relation

$$\begin{aligned} P(\omega) &= \int_{-\infty}^{\infty} R_{xx}(\tau) e^{j(\omega\tau)} d\tau \\ &= X(\omega) X^*(\omega) \\ &= |X(\omega)|^2 \end{aligned} \quad (9)$$

where  $R_{xx}(\tau)$  is the autocorrelation function of  $x(t)$ . Here,  $X(\omega)$  is the Fourier transform of  $x(t)$  and  $( )^*$  denotes the complex conjugate. It is known that the use of power spectrum is a significant disadvantage in that the Gaussian additive noise superimposed on the signal remains in the power spectrum domain. Moreover, the magnitude of the second order component generated by the nonlinear effect is so small compared with the fundamental component that it might be suppressed by the noise remaining in the power spectrum domain.

In this paper, a new signal processing method based on the bispectral analysis was used to overcome this drawback. Bispectrum is defined as the two-dimensional Fourier transform of the third order correlation function:

$$B_{xxx}(\omega_m, \omega_n) = \int_{-\infty}^{\infty} \int_{-\infty}^{\infty} R_{xxx}(\tau_1, \tau_2) e^{j(\omega_m \tau_1 + \omega_n \tau_2)} d\tau_1 d\tau_2 \quad (10)$$

where  $R_{xxx}(\tau_1, \tau_2)$  is the third-order correlation function. Because  $R_{xxx}$  of the Gaussian noise becomes zero, Gaussian noise can be eliminated completely in the bispectrum domain. Also, because the bispectrum is non-negligible only when three frequency component of  $\omega_m$ ,  $\omega_n$ , and  $\omega_m + \omega_n$  have a special phase relation to each other, it is very useful in detecting small high order harmonic components induced by the nonlinear ultrasonic effect.

For the time signals composed of Eq. (6), the

**Table 1** Chemical compositions of 1Cr-1Mo-0.25V rotor steel (unit: wt %)

C	Si	Mn	P	S	Ni	Cr	Mo	V	As	Sn	Sb
0.31	0.23	0.76	0.006	0.001	0.36	1.11	1.32	0.27	0.006	0.005	0.001

**Table 2** Mechanical properties of 1Cr-1Mo-0.25V rotor steel

Temperature (°C)	Yield Strength (MPa)	Tensile Strength (MPa)	Elongation (%)	Area Reduction (%)	Hardness (Hv)
24	665.2	823.1	18.8	59.4	266
538	533.5	580.6	22.7	55.5	-

power spectral density functions at frequencies  $\omega_1$  and  $\omega_2=2\omega_1$  are given by

$$P(\omega_1) = |X(\omega_1)|^2 = A_1^2, \quad P(\omega_2) = |X(\omega_2)|^2 = A_2^2 \quad (11)$$

The magnitude of the bispectrum for the same signal at  $\omega_m = \omega_1$ ,  $\omega_n = \omega_1$  is obtained as

$$|B(\omega_1, \omega_1)| = |X(\omega_1)X(\omega_1)X^*(\omega_1 + \omega_2)| = A_1^2 A_2 \quad (12)$$

From Eqs. (8), (9) and (12), the normalized nonlinearity parameter  $\beta'$  can be obtained as follows:

$$\beta' = \frac{A_2}{A_1^2} = \frac{|B(\omega_1, \omega_1)|}{P(\omega_1)^2} \quad (13)$$

## 4. Samples and Experimental Technique

### 4.1 Materials and impact tests

The test material used in this work is 1Cr-1Mo-0.25V rolled steel, which has been widely used as turbine rotor materials of power plants. The chemical compositions and mechanical properties of this material are listed in Tables 1 and 2, respectively.

The generation of fracture toughness data for in-service rotors at various exposure times is generally impractical. Therefore, fracture toughness specimens were prepared by isothermal heat treatment at 630°C, which is higher than the actual service temperature 538°C. Table 3 shows the heat treatment times of six processed specimens at 630°C and their corresponding exposure times at 538°C. For given service time at 538°C, the heat treatment time of each specimen at 630°C was determined by the self diffusion theory of Fe

**Table 3** Aging time at 630°C and equivalent service exposure time at 538°C

Service exposure time at 538°C (hr)	25,000	50,000	75,000	100,000	200,000	300,000
Aging time at 630°C (hr)	453	933	1,322	1,820	3,640	5,460

(Abdel-Latif et al., 1981). For instance, the specimen heat-treated at 630°C for 453 hr contains the same amount of Fe as the actual material operated at 538°C for 25,000 hr.

The Charpy V-notch (CVN) impact tests were performed to evaluate the ductile-to-brittle transition in these steels through the fracture appearance transition temperature (FATT). The FATT data in all cases have been generated according to ASTM E-23 specifications. More specifically, TL type specimens (transverse loading - longitudinal crack), 10mm × 10mm × 55mm in size, were fabricated from the rolled plate. In this case, the specimen length direction is perpendicular to the rolling direction, and the fracture surface is parallel to the grain elongation direction. Before CVN testing, specimens were kept for more than 10 minutes at each test temperature  $\pm 2^\circ\text{C}$  in a controlled furnace. Impact tests were then completed within 5 seconds after they were taken out of the furnace. A total of 8 samples for each stage of service exposure time were used to obtain a curve of absorbed energy vs. temperature in the range of  $-100$  to  $300^\circ\text{C}$ . The midpoint of energy curve taken as the average of the upper shelf and the lower shelf was used to define a ductile-to-brittle transition temperature (DBTT). FATT can be defined as the transition temperature for a fracture appearance corresponding to 50% ductile-50% cleavage. In this study, the FATT was taken to be equal to the DBTT. One of the fractured CVN pieces tested in the vicinity of the DBTT was used for the ultrasonic test to provide the nonlinearity parameter for each stage of service exposure time.

### 4.2 Measurement system

Figure 2 shows the schematic diagram of experimental system constructed to measure the

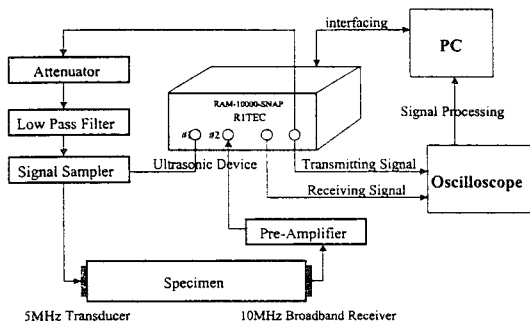

Fig. 2 Measurement system for higher harmonic components

magnitude of second order harmonic components in the received ultrasonic signals. An ultrasonic signal analysis device, the RAM 10000 system (RITEC, USA) was employed for this purpose. A 5 MHz broadband transducer was used as a transmitter. The waveform of transmitting signal was a tone burst with 20 cycles. A broadband transducer with a center frequency of 10 MHz was used as a receiver to measure the second order component more efficiently. The attenuator, filter and amplifier are devices to adjust the characteristics of transmitting and receiving signals. The received signal was A/D converted and signal processing was carried out on a personal computer for estimating the magnitude of second order harmonic components in the frequency domain.

## 5. Results and Discussion

The FATT values obtained through the CVN impact tests are shown in Fig. 3 as a function of exposure time. From the results shown in Fig. 3, it is evident that there is a significant change in the FATT during the early stage of exposure time. It increases with time of exposure up to 50,000 hr and then stays fairly constant up to 200,000 hr. As the exposure time further increases, there is an indication of reduction in the FATT at the end of 300,000 hr. The FATT at 75,000 hr of exposure is lower compared to that after 50,000 hr of aging. The FATT behavior observed here is consistent with other investigations performed on the 18 rotor steel samples aged at 454°C for various

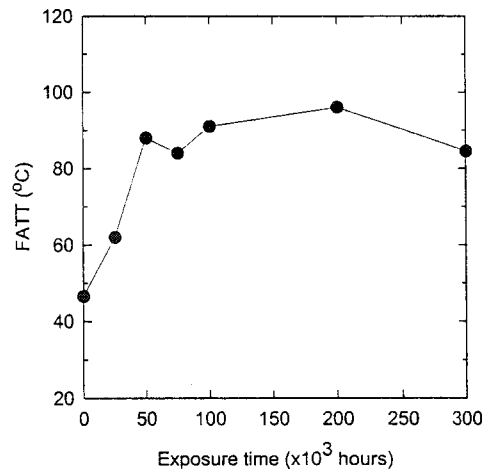

Fig. 3 Dependence of FATT on aging time

lengths of time up to 95,000 hr (Viswanathan and Gehl, 1991). These results indicate that the maximum embrittlement of in-service rotors is reached in about 5 years and the actual service life beyond this duration has little effect on embrittlement.

In Fig. 4, the measured nonlinearity parameter,  $\beta'$ , is plotted as a function of exposure time. Here, the measurement repeatability was found to be better than 5%. Figure 4 shows a significant change in  $\beta'$  during the early stage of exposure time. There is an approximately 33% increase in the value of  $\beta'$  up to 75,000 hr. It then stays fairly constant up to 200,000 hr. There is an indication of minor increase in its value beyond this exposure time. The initial 33% increase is a significant change; however, it seems to be less sensitive to the thermal process beyond 75,000 hr of the exposure time. The electrical resistivity was also measured on these samples using a DC potential drop measurement system (Nahm et al., 1998). The measurement results showed a similar behavior, i. e., a significant decrease up to 75,000 hr, staying fairly constant up to 200,000 hr, and an indication of decrease at 300,000 hr.

Based on these results, the significant change in  $\beta'$  in the early stage of the process can be explained as a result of an increase in the grain boundary segregation of impurity elements present in the steel (Viswanathan and Gehl, 1991). As the increase in the grain boundary

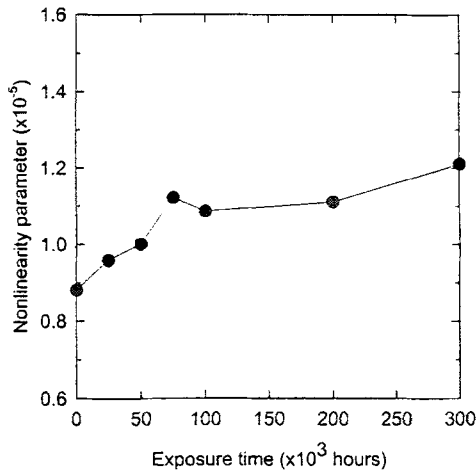

Fig. 4 Dependence of ultrasonic nonlinearity parameter on aging time

segregation saturates,  $\beta'$  becomes stable. This explanation can also be applied to the observed effects of exposure time on the FATT.

Several correlations between fracture toughness  $K_{Ic}$  and impact test results have been proposed in the literature. Among these correlations, the excess temperature (i.e.,  $K_{Ic}$  test temperature-FATT) method was chosen in this work to estimate the  $K_{Ic}$  from the CVN testing FATT or from the nonlinearity parameter. Jones has proposed the following correlation between  $K_{Ic}$  and excess temperature (Viswanathan and Gehl, 1991):

$$K_{Ic} = 6600 / [60 - (T - \text{FATT})] \quad (14)$$

where  $K_{Ic}$  is expressed in  $\text{MPa m}^{1/2}$ , and the  $K_{Ic}$  test temperature  $T$  and FATT are expressed in  $^{\circ}\text{C}$ . This correlation was based on a large amount of CVN testing and  $K_{Ic}$  data collected on large alloy forgings. The  $K_{Ic}$  values corresponding to the FATT data presented in Fig. 3 were estimated by this equation and shown in Fig. 5. Also included in Fig. 5 is the scatterband of  $K_{Ic}$  versus the excess temperature for commercial purity CrMoV rotors (Viswanathan and Gehl, 1991). This scatterband was based on numerous data points obtained on a number of retired CrMoV rotors. The estimated  $K_{Ic}$  data points are found to fit into the narrow scatterband. Furthermore, they nearly coincide with the lower limit of the  $K_{Ic}$  versus excess temperature scatterband for CrMoV.

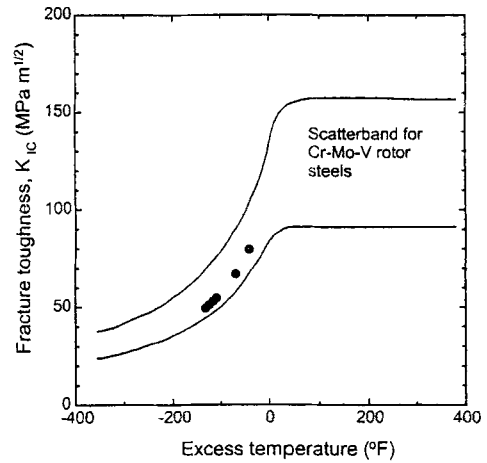

Fig. 5 Estimated fracture toughness based on the  $K_{Ic}$  versus excess temperature correlations and the  $K_{Ic}$  scatterband for retired CrMoV rotor steels

We now develop a methodology for estimating the  $K_{Ic}$  of embrittled rotor steels in a nondestructive manner. First, the correlations between the nonlinearity parameter and the FATT are sought. The FATT values can then be used to estimate  $K_{Ic}$ , using the  $K_{Ic}$  versus excess temperature correlation that is available in the literature for CrMoV rotor steel. As discussed previously, since overall behavior of the nonlinearity parameter and the CVN testing FATT is similar in terms of the exposure time, a good correlation between these two parameters should be expected. The nonlinearity parameter versus the FATT correlation was found from Figs. 3 and 4, and the results are shown in Fig. 6. Figure 7 shows the correlation between the nonlinearity parameter and  $K_{Ic}$ , which was obtained from Fig. 6 and Eq. (14). Both the  $K_{Ic}$  and the nonlinearity parameter change a lot at the early part of aging time (up to about 75,000 hr). After this time, however, both parameters show almost no change. The nondestructively estimated results of  $K_{Ic}$  values versus excess temperature can also be found in Fig. 5. As noted previously, all the estimated  $K_{Ic}$  values fall within the  $K_{Ic}$  scatterband for retired CrMoV rotors. Actually they nearly coincide with the lower limit line of the  $K_{Ic}$  versus excess temperature scatterband. Results of the present study show that the fracture toughness of CrMoV

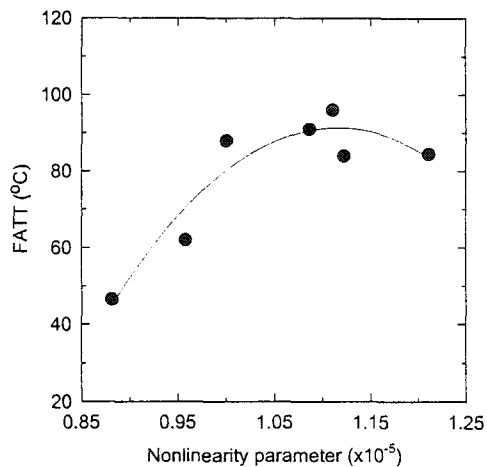

Fig. 6 Correlations between the nonlinearity parameter and the FATT

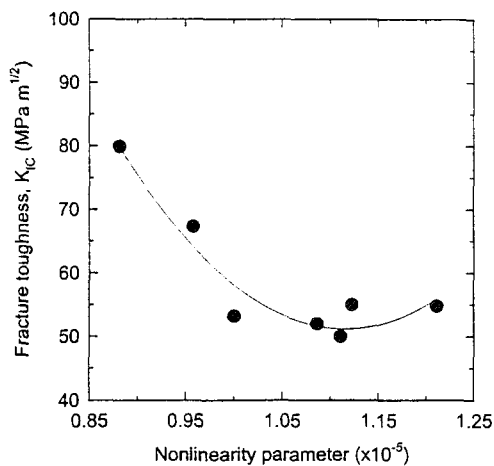

Fig. 7 Correlations between the nonlinearity parameter and the fracture toughness

rotors can be nondestructively predicted based on a knowledge of the ultrasonic nonlinearity parameter and its correlation to FATT.

## 6. Conclusions

A nondestructive ultrasonic procedure for estimating the fracture toughness of thermally embrittled CrMoV rotor steel has been developed. The procedure consists of estimating the FATT based on a correlation between nonlinearity parameter and FATT. The FATT values can then be used to estimate  $K_{Ic}$ , using the  $K_{Ic}$  versus

excess temperature (i.e.,  $T$ -FATT) correlation that is available in the literature for CrMoV rotor steel. All the nondestructively estimated  $K_{Ic}$  values fell within the  $K_{Ic}$  scatterband obtained from a number of retired rotors. Actually they nearly coincided with the lower limit line of the scatterband. Results of the present study show that the fracture toughness of rotors can be nondestructively evaluated if the correlation between nonlinearity parameter and FATT is known.

## Acknowledgement

This work was partially supported by Wonkwang University in the 2001 academic year.

## References

- Abdel-Latif, A. M., Corbett, J. M., Sidey, D. and Taplin, D. M. R., 1981, "Effects of Microstructural Degradation of Creep Life Prediction of 2.25Cr-1Mo Steel," *Proc. of 5<sup>th</sup> Int. Conf. Fracture (ICF5)*, Cannes, France, Vol. 4, pp. 1613~1620.
- Foulds, J. and Viswanathan, R., 1994, "Small Punch Testing for Determining the Material Toughness of Low Alloy Steel Components in Service," *Journal of Engineering Materials and Technology*, Vol. 116, No. 4, pp. 457~464.
- Frouin, J., Sathish, S., Matikas, T. E. and Na, J. K., 1999, "Ultrasonic Linear and Nonlinear Behavior of Fatigued Ti-6Al-4V," *Journal of Materials Research*, Vol. 14, No. 4, pp. 1295~1298.
- Ha, J. S. and Fleury, E., 1998, "Small Punch Tests to Estimate the Mechanical Properties of Steels for Steam Power Plant: II. Fracture Toughness," *International Journal of Pressure Vessels and Piping*, Vol. 75, pp. 707~713.
- Hikata, A. and Chick, B. B. and Elbaum, C., 1965, "Dislocation Contribution to the Second Harmonic Generation of Ultrasonic Waves," *Journal of Applied Physics*, Vol. 36, No. 1, pp. 229~236.
- Holzmann, N., Dlouhy, I., Vlach, B. and Krumpos, J., 1996, "Degradation of Mechanical

Properties of Cr-Mo-V and Cr-Mo-V-W Steam Turbine Rotors After Long-Term Operation at Elevated Temperatures. Part II: Fracture Toughness, Correlation of Fracture Toughness with Charpy V-notch Results," *International Journal of Pressure Vessel & Piping*, Vol. 68, pp. 113~120.

Jhang, K. Y. and Kim, K. J., 1999, "Evaluation of Material Degradation Using Nonlinear Acoustic Effect," *Ultrasonics*, Vol. 37, pp. 39~44.

Nahm, S. H., Kim, A. and Yu, K. M., 1998, "Nondestructive Evaluation of Toughness Degradation of 1Cr-1Mo-0.25V Steel Using Electrical Resistivity," *Proceedings of KSME A*, Vol. 22, No. 5, pp. 814~820 (in Korean).

Nishiyama, Y., Fukaya, K., Suzuki, M., Eto, M. and Shoji, T., 1994, "Electrochemical Monitoring of Aging Embrittlement of 2 1/4Cr-1Mo Steel for Gas-Cooled Reactor Pressure Boundary Components," *Theoretical and Applied Fracture Mechanics*, Vol. 21, No. 1, pp. 51~57.

Rothenfusser, M., Mayr, M. and Baumann, J., 2000, "Acoustic Nonlinearities in Adhesive Joints," *Ultrasonics*, Vol. 38, pp. 322~326.

Shekhter, A., Croker, A. B. L., Hellier, A. K., Moss, C. J. and Ringer, S. P., 2000, "Towards the

Correlation of Fracture Toughness in an Ex-Service Power Generating Rotor," *International Journal of Pressure Vessels and Piping*, Vol. 77, pp. 113~116.

TenCate, J. A. and Van Den Abble, K. E., 1996, "Laboratory Study of Linear and Nonlinear Elastic Pulse Propagation in Sandstone," *Journal of the Acoustical Society of America*, Vol. 100, No. 3, pp. 1383~1389.

Viswanathan, R. and Bruemmer, S. M., 1985, "In-Service Degradation of Toughness of Steam Turbine Rotors," *Journal of Engineering Materials and Technology*, Vol. 107, pp. 317~24.

Viswanathan, R. and Gehl, S., 1991, "A Method for Estimation of the Fracture Toughness of CrMoV Rotor Steels Based on Composition," *Journal of Engineering Materials and Technology*, Vol. 113, No. 2, pp. 263~270.

Yost, W. T., Cantrell, J. H. and Na, J. K., 2001, "Nonlinear Ultrasonic Pulsed Measurements and Applications to Metal Processing and Fatigue," *in Review of Progress in Quantitative Nondestructive Evaluation*, Vol. 20, eds. D. O. Thompson and D. E. Chimenti, American Institute of Physics, pp. 1268~1275.